

FM 105°C低漏电标准品 (CD113H)

- 极低漏电特性，标准尺寸，105°C 1000 小时。Extremely low leakage current, standard size, 105°C 1000 hrs.
- 适用于电视机频道转换或小信号输入回路。
Used in TVs frequency channel conversion or weak signal import loop circuits.
- 符合 RoHS。RoHS Compliant.

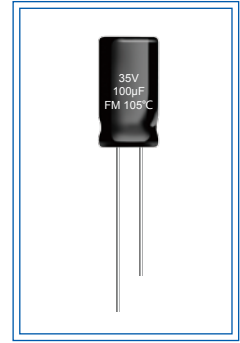

主要技术性能 Specifications

项目 Item	特性 Performance Characteristics									
工作温度范围 Operating Temperature Range	-40~+105°C									
额定电压范围 Rated Voltage Range	6.3~100V									
标称容量范围 Nominal Capacitance Range	0.1~3300µF									
标称容量允许偏差 Capacitance Tolerance	±20%(+20°C, 120Hz)									
漏电流 Leakage Current	1 ≤ 0.002CV or 0.4 (µA) 2分钟 (at 20°C, after 2 minutes) 取较大者 (whichever is greater)									
损耗角正切值 (tgδ) Dissipation Factor (+20°C, 120Hz)	U _R (V)	6.3	10	16	25	35	50	63	100	
	tgδ	0.28	0.24	0.2	0.16	0.14	0.12	0.12	0.10	
温度特性 Temperature Characteristics (Impedance ratio at 120Hz)	U _R (V)	6.3	10	16	25	35	50	63	100	
	Z-25°C / +20°C	4	3	2	1.5	1.5	1.5	1.5	1.5	
	Z-40°C / +20°C	8	6	4	4	3	3	3	3	
耐久性 Load Life	+85°C加额定电压 1000 小时，恢复 16 小时后： After applying rated voltage for 1000 hours at +85°C and then resumed 16 hours： 电容变化率 Capacitance change : ±20% 初始测量值以内 ±20% of the initial measured value 漏电流 Leakage current : ≤初始规定值 ≤ the initial specified value 损耗角正切值 Dissipation factor : ≤ 2 倍初始规定值 ≤ 200% of the initial specified value									
高温贮存 Shelf Life	+105°C, 1000 小时贮存后，加额定工作电压处理 30 分钟，恢复 16 小时后： After storage for 1000 hours at +105°C, U _R to be applied for 30 minutes and then resumed 16 hours： 电容变化率 Capacitance change : ±20% 初始测量值以内 ±20% of the initial measured value 漏电流 Leakage current : ≤初始规定值 ≤ the initial specified value 损耗角正切值 Dissipation factor : ≤ 2 倍初始规定值 ≤ 200% of the initial specified value									

外形图及尺寸 Diagram of Dimensions

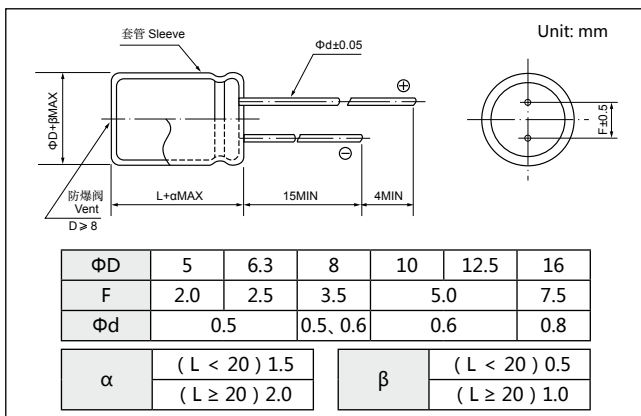

纹波电流修正系数 Multiplier for Ripple Current

频率系数 Frequency coefficient	Frequency (Hz)			
Cap (µF)	60	120	1k	≥ 10k
0.1~22	0.8	1.0	1.5	1.7
33~100	0.8	1.0	1.4	1.5
220~3300	0.8	1.0	1.3	1.35

额定值标准 Standard Size

C _R (μF)	U _R Code	6.3V		10V		16V		25V	
		0J		1A		1C		1E	
4.7	4R7							5×11	38
6.8	6R8					5×11	36	5×11	47
10	100					5×11	43	6.3×11	60
15	150					5×11	53	6.3×11	72
22	220			5×11	56	6.3×11	74	8×11.5	99
33	330			6.3×11	79	6.3×11	90	8×11.5	119
								5×11	38
47	470			6.3×11	94	8×11.5	127	10×12.5	172
68	680			6.3×11	113	8×11.5	153	10×12.5	207
100	101			8×11.5	160	10×12.5	220	10×16	270
								6.3×11	75
150	151	8×11.5	183	10×12.5	236	10×16	296	10×20	368
220	221	10×12.5	260	10×16	310	10×20	390	12.5×20	510
330	331	10×16	350	10×20	420	12.5×20	550	12.5×25	680
470	471	10×20	460	12.5×20	570	12.5×20	650	16×25	940
680	681	10×20	554	12.5×20	686	12.5×25	895	16×30	1246
1000	102	12.5×25	840	12.5×25	910	16×25	1210	16×35	1580
1500	152	12.5×25	1029	16×25	1297	16×30	1623		
2200	222	16×25	1440	16×30	1710	16×35	2200		
3300	332	16×35	2037	16×35	2209				

C _R (μF)	U _R Code	35V		50V		63V		100V	
		1V		1H		1J		2A	
0.1	0R1			5×11	6				
0.15	R15			5×11	7				
0.22	R22			5×11	8				
0.33	R33			5×11	10				
0.47	R47			5×11	12				
0.68	R68			5×11	14				
1.0	010			5×11	17				
1.5	1R5			5×11	21			5×11	23
2.2	2R2			5×11	26			6.3×11	30
3.3	3R3			5×11	32	6.3×11	36	6.3×11	36
4.7	4R7	5×11	34	6.3×11	43	6.3×11	43	8×11.5	51
				5×11	30				
6.8	6R8	5×11	41	6.3×11	52	6.3×11	52	10×12.5	73
10	100	6.3×11	57	8×11.5	75	8×11.5	75	10×16	97
				6.3×11	60				
15	150	8×11.5	82	8×11.5	92	10×12.5	109	10×20	130
22	220	8×11.5	99	10×12.5	131	10×16	144	10×20	158
				6.3×11	80				
33	330	10×12.5	144	10×16	176	10×16	176	10×20	193
47	470	10×12.5	172	10×16	210	10×20	230	12.5×25	288
68	680	10×16	227	10×20	277	10×20	277	12.5×25	346
100	101	10×20	300	12.5×20	380	12.5×25	420	16×25	488
150	151	12.5×20	422	12.5×25	514	12.5×25	514	16×30	654
220	221	12.5×25	550	16×25	720	16×30	792		
330	331	16×25	790	16×30	970	16×35	1018		
470	471	16×25	940	16×35	1210				
680	681	16×31	1246						

额定纹波电流 Rated ripple current(mA,+105°C,120Hz)

可根据客户需要定制产品 Customer products are available on request.